

**CABLE TRAY SYSTEMS
LOCAL SWITCHBOARD
STEEL FABRICATION**

smc

SIAM METAL WORKS INDUSTRIES



Business Profile

Siam Metal Works Industries Company Limited, established in 1991, is the leading expert in cable tray systems manufacturing with a registered capital of THB 24,000,000. Our factory is of a high standard locating on the spacious area of 13,500 square meters, equipped with modern machinery, production system controlled by computers and a group of long experienced production teamwork. We put strong emphasis on quality of our works as well as quickness and prompt service to ensure total satisfaction for all our customers.

Contents

2 **Business Profile**
About our company

4 **Certificates**
Product is guaranteed

6 **Process**
System to make our product

Cable Tray Systems

10 **Ladder Type**

13 **Ventilated Type** CORRUGATED BOTTOM

16 **Perforated Type** SOLID BOTTOM

19 **Wireway Type**

22 **C-Channel Type**

Support System

25 **Project References**



Certificate

Reference No. SPT-13/45

Page 1 of 6



FACULTY OF ENGINEERING
CHULALONGKORN UNIVERSITY
MATERIAL TESTING LABORATORY

- TYPE OF TEST** : RATED LOAD CAPACITY OF METAL CABLE TRAY SYSTEMS
- TEST SPECIMENS** : METAL CABLE TRAY SYSTEMS
Two types of specimens tested in this report are as follows:
1) Ventilated Trough Type Cable Trays
2) Ladder Type Cable Trays
Details of the specimens are given in Tables 1-2 and Figs. 1-2.
- CLIENT** : SIAM METAL WORKS INDUSTRIES CO.,LTD.
- BRAND** : 
- DATE OF TEST** : 8 February 2002
- TEST WEIGHTS** : The loading materials are metal steel bars with the average weight of 4.5 kg, a maximum width of 125 mm, and a maximum length of 300 mm. The loading materials meet the requirements of NEMA VE 1-1998 Section 5 Clause 5.2.6 (c).
- TEST METHOD** : Testing procedures follow NEMA Standards Publication VE 1-1998 Section 4: Construction and Section 5: Tests. The testing procedures can be summarized as follows:
1) The specimen is tested in accord with NEMA VE 1-1998 Section 5 Clause 5.2.8: Loading to Destruction (Method A).
2) Each specimen is supported on two 2-1/2" diameter round steel bars which are 3.0 m apart. Details of the test setup and the support are shown in Figs. 3-4.
3) The loading materials were uniformly applied across the length and the breadth of the specimen. The loading materials were arranged across the tray with a minimum of 10 mm between stacks to avoid bridging transversely.
4) The load is incrementally increased with at least 10 increments that are approximately equal. The total weight of the loading material on the cable tray, prior to addition of the incremental weight that causes the destruction, is considered to be the destruction load.
- TEST RESULTS** : The destruction load and the rated load capacity of the specimens are as stated:
(The test results are good only for the specimen tested.)

Trough Type Cable Tray (W x H x L) (mm)	Destruction Load (kg/m)	Rated Load Capacity (kg/m)	Ladder Type Cable Tray (W x H x L) (mm)	Destruction Load (kg/m)	Rated Load Capacity (kg/m)
200 x 100 x 3000	285	190	200 x 100 x 3000	465	310
300 x 100 x 3000	270	180	300 x 100 x 3000	420	280
400 x 100 x 3000	240	160	400 x 100 x 3000	420	280
500 x 100 x 3000	315	210	500 x 100 x 3000	405	270
600 x 100 x 3000	270	180	600 x 100 x 3000	405	270
700 x 100 x 3000	240	160	700 x 100 x 3000	420	280
800 x 100 x 3000	300	200	800 x 100 x 3000	375	250
900 x 100 x 3000	360	240	900 x 100 x 3000	360	240
1000 x 100 x 3000	315	210	1000 x 100 x 3000	420	280

(Associate Prof. Dr. Boonchai Sittimannaithum)
On behalf of Head of Civil Engineering Department

Date: February 11, 2002

Tested by: 
(Dr. Thanysat Pongasiri)



Certificate TH13/6988



The management system of
**SIAM METAL WORKS INDUSTRIES
CO., LTD.**

23/248-249 Moo 8, Soi Pongsirchai 2, Petchkasem Rd.,
T. Om-Yai, A. Sampran, Nakhon Pathom 73160, Thailand



has been assessed and certified as meeting the requirements of

ISO 9001:2015

For the following activities

The scope of registration appears on page 2 of this certificate.

This certificate is valid from 10 November 2017 until 4 April 2019 and
remains valid subject to satisfactory surveillance audits.
Re certification audit due before 8 March 2019
Issue 3. Certified since 4 April 2013



Additional site details are listed on the subsequent page.

Authorised by



0005

SGS United Kingdom Ltd
Rossmore Business Park, Ellesmere Port, Cheshire, CH65 3EN, UK
t +44 (0)151 350-6666 f +44 (0)151 350-6600 www.sgs.com

IAF SGS 9001 2015 0117 M2

Page 1 of 2



This document is issued by the Company subject to its General Conditions of Certification Services accessible at www.sgs.com/terms_and_conditions.htm. Attention is drawn to the limitations of liability, indemnification and jurisdictional issues established therein. The authenticity of this document may be verified at <http://www.sgs.com/en/certified-clients-and-products/certified-client-directory>. Any unauthorized alteration, forgery or fabrication of the content or appearance of this document is unlawful and offenders may be prosecuted to the fullest extent of the law.

Process

QUALITY MATERIAL



SMC assures our material meet the minimum yield and tensile strengths of applicable ASTM standards. All cable tray side rails, rungs and splice plates are numbered for material trace ability, and uniquely formed to increase strength and withstand abuse.

Material	Material Specification	Advantage
- Steel	ASTM A 570&A611 (Plain Steel) ASTM A 446 (Pre-Galvanized)	Electric shielding, finish option, Low thermal expansion
- Electrogalvanized		Corrosion resistant
- Galvanized Sheet	JIS G 3302-1991	Highly corrosion resistant
- Aluzinc Sheet		Oxidation resistant at high temperature, and galvanic protection
- Stainless	SS 304 / SS 316	None corrosion

UNIQUE PAINTING PROCESS

Epoxy Powder Paint Process

1. Cleaning and Pre-treatment

All steel materials will be cleaned and pre-treated with zinc phosphate solution for dust and grease removal, enhancing the greater adhesion of color on metal surface, and a better rust protection.

- Epoxy Powder Paint

After cleaning and pretreatment process, the materials will be coated with epoxy powder using electrostatic process. With this unique process, it provides hard flim surface, resist rust and scratches, and corrosion caused by chemical. Also, it gives a better adhesion to most metal surfaces, cover edge and even in recessed area consistently.



Item	Specification	Result	Test Method
impact resistant	There shall be no cracks or peels. (5/8" 0x3 lbs x 50")	Pass	ASTM D2974
Erichsen Test	5 mm. or more	Pass	ISO 1520
Bend Test	There shall be no cracks or peels. (6mm.in diameter)	Pass	ISO 1519
Pencil Hardess	Mitsubishi Uni HB - 2H	Pass	ATSM D3363-05
Adhesion	2 mm., cross-cut 100/100 or GT-01	Pass	ISO 2409
UV Resistant	Color and gross stability Density 1.2-1.7 Kg/dm3	Pass	ASTM D5894
Corrision Protection	Heat Resistant	Good	ASTM B117-73

Process

Hot-Dip Galvanizing Process (HDG)

2. Hot-Dip Galvanized After Fabrication

HDG cable tray products give the coating thickness according to ASTM A123 standard on each side. This method is recommended for prolonged outdoor exposure, aggressive industrial environment, and petrochemical plants especially.

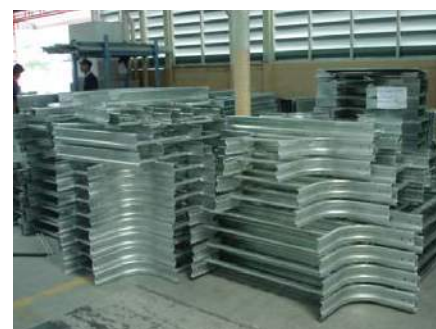

Coating Thickness Conform to ATSM A123/A 123 M.

Steel Category (Not Centrifuged)	Minimum Average Coating Thickness(Micron)				
	Steel Thickness Under 1.60 mm.	Steel Thickness 1.60 mm. To Under 3.20mm.	Steel Thickness 3.20 mm. to 4.80 mm.	Steel Thickness > 4.80 mm. to Under 6.40 mm.	Steel Thickness 6.40 mm. And OVER
Structural Shapeand Plate	45	65	75	85	100
Strip and Bar	45	65	75	85	100
Pipe and Tubing	45	45	75	75	75
Wire	35	50	60	65	80
Reinforcing Bar	-	-	-	-	100
Remark	The Table Value For Specimen Test				

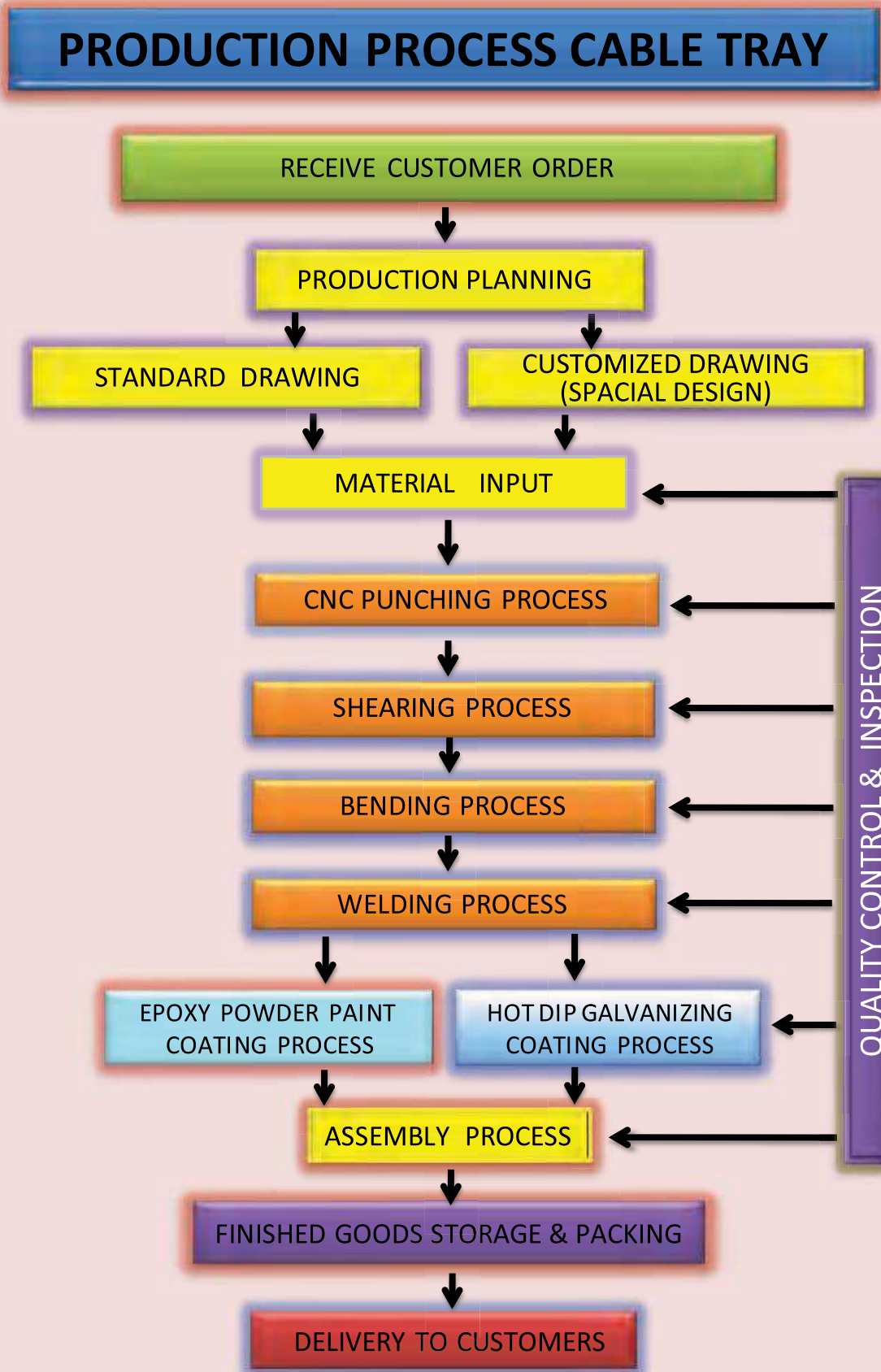

Ladder Type HEAVY DUTY



STRAIGHT SECTION

Manufacturing Standard Specification

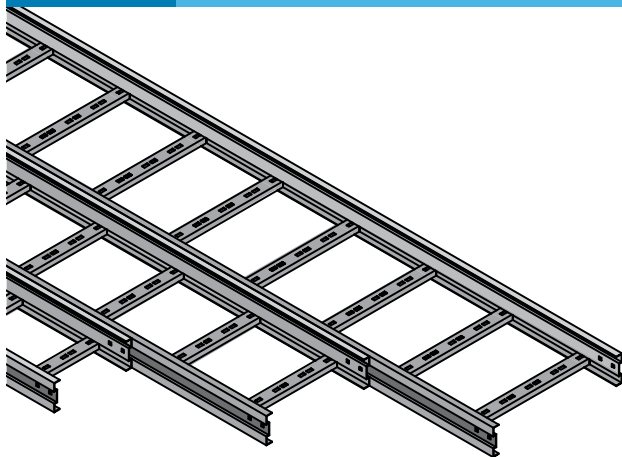

Description
Application
Material Selection

Deformation Standard
Finishing Standard

Length (mm.)
Height (mm.)
Thickness (mm.)
Side Rail Profile
Assembly

Rung Space

LADDER TYPE
Indoor & Outdoor (Heavy Duty)
• Hot Roll Mild Steel
• Stainless 304/L, 316/L
• Electro Galvanized
• Galvanized Sheet
NEMA VE-01 Certified
Epoxy Powder Coating-ASTM D687
Hot Dip Galvanized-ASTM A123

3000	6000 (HDG ONLY)
100	150
2.0	

(Side Rail: E-Shape in)
• Bolt & Nut Connection
• Welding
300 mm.

(NEMA-NE01 Standard)

Detail :

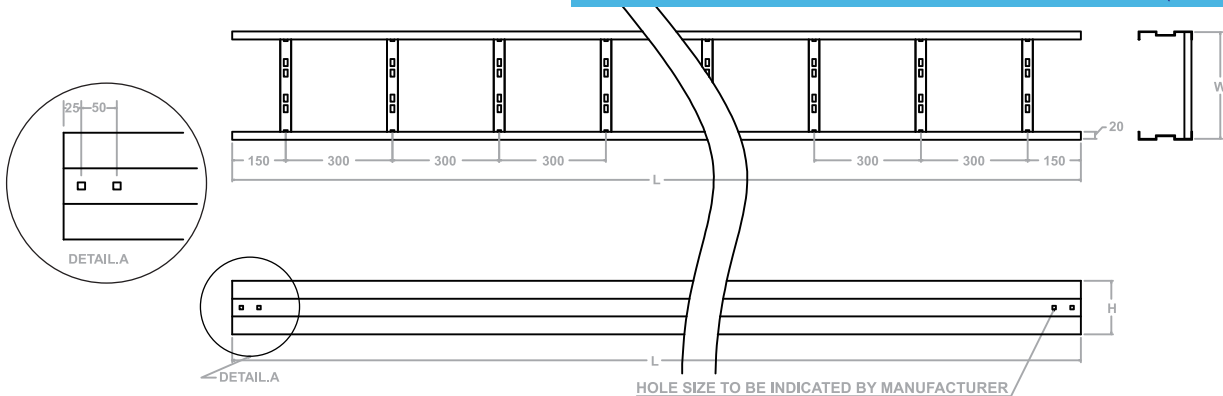

CODE NO. EPOXY POWDER COATING	CODE NO. HOT DIP GALVANIZED	LADDER SIZE W x H x L (MM.)	WEIGHT/KG/EA		
			LADDER		COVER
			T = 2.0	T = 1.6	T = 2.0
LP 01	LH 01	100 X 100 X 3000	16.90	5.20	6.50
LP 02	LH 02	200 X 100 X 3000	18.02	8.97	11.21
LP 03	LH 03	300 X 100 X 3000	19.14	12.74	15.92
LP 04	LH 04	400 X 100 X 3000	20.79	16.50	20.63
LP 05	LH 05	500 X 100 X 3000	22.17	20.27	25.34
LP 06	LH 06	600 X 100 X 3000	23.55	24.01	30.05
LP 07	LH 07	700 X 100 X 3000	24.93	27.81	34.76
LP 08	LH 08	800 X 100 X 3000	26.31	31.58	39.35
LP 09	LH 09	900 X 100 X 3000	27.69	35.34	44.18
LP 10	LH 10	1000 X 100 X 3000	29.08	39.11	48.89
LP 12	LH 12	1200 X 100 X 3000	33.23	46.65	58.31

*L = Ladder, P = Epoxy Powder Coating, H = Hot Dip Galvanized

Ladder Type HEAVY DUTY



FITTINGS

HORIZONTAL CROSS

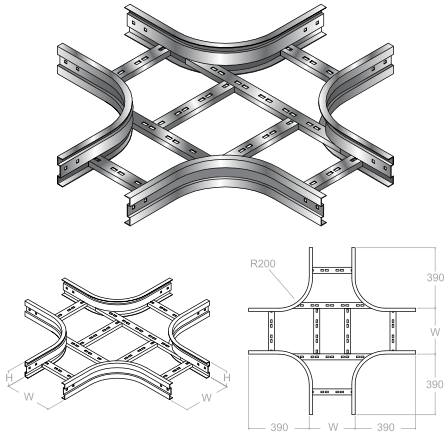

CODE NO. EPOXY POWDER COATING	CODE NO. HOT DIP GALVANIZED	LADDER SIZE (MM.)
HX-LP	HX-LH	W x H

HORIZONTAL REDUCE

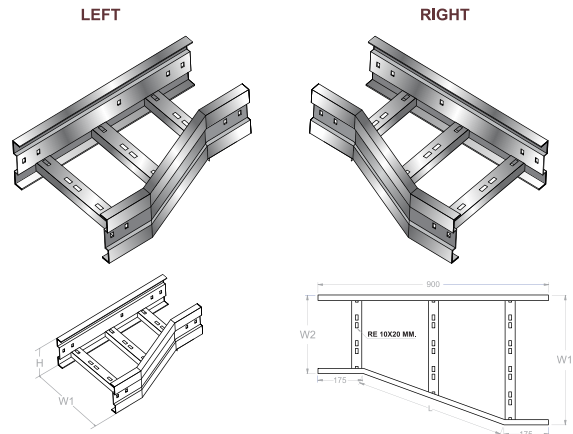

CODE NO. EPOXY POWDER COATING	CODE NO. HOT DIP GALVANIZED	LADDER SIZE (MM.)
HR-LP	HR-LH	W1, W2 x H

HORIZONTAL TEES

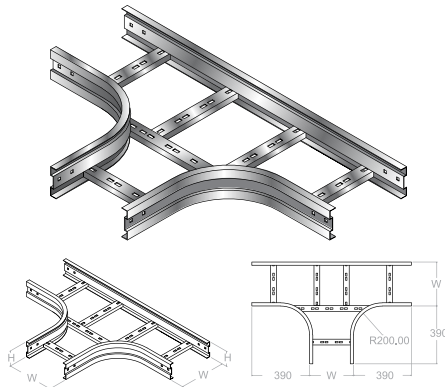

CODE NO. EPOXY POWDER COATING	CODE NO. HOT DIP GALVANIZED	LADDER SIZE (MM.)
HT-LP	HT-LH	W x H

VERTICAL INSIDE

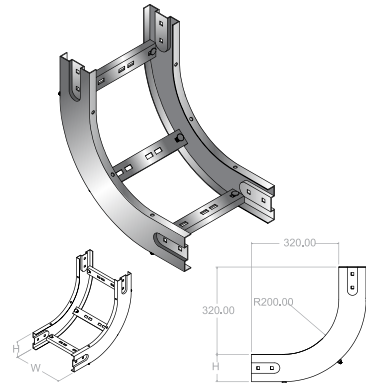

CODE NO. EPOXY POWDER COATING	CODE NO. HOT DIP GALVANIZED	LADDER SIZE (MM.)
90VI-LP	90VI-LH	W x H

HORIZONTAL BEND

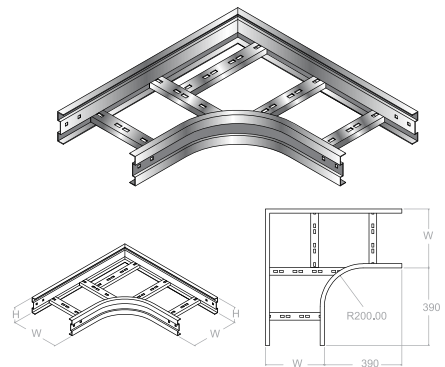

CODE NO. EPOXY POWDER COATING	CODE NO. HOT DIP GALVANIZED	LADDER SIZE (MM.)
90HB-LP	90HB-LH	W x H

VERTICAL OUTSIDE

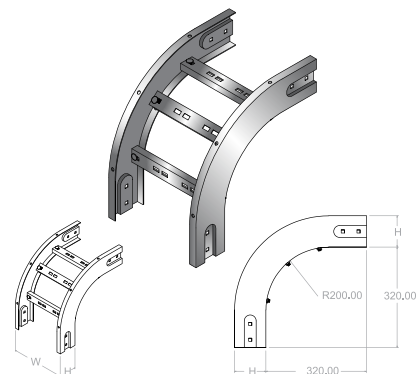

CODE NO. EPOXY POWDER COATING	CODE NO. HOT DIP GALVANIZED	LADDER SIZE (MM.)
90VO-LP	90VO-LH	W x H

*L = Ladder, P = Epoxy Powder Coating, H = Hot Dip Galvanized

Ladder Type



ACCESSORIES

SPLICE PLATE (OUT)

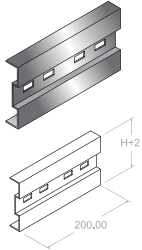

CODE NO. EPOXY POWDER COATING	SP-LP (OUT)
CODE NO. HOT DIP GALVANIZED	SP-LH (OUT)
THICKNESS MM.	2.0
WEIGHT KG.	0.52

VERTICAL ADJUSTABLE

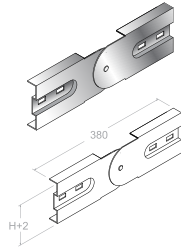

CODE NO. EPOXY POWDER COATING	VAJ-LP
CODE NO. HOT DIP GALVANIZED	VAJ-LH
THICKNESS MM.	2.0
WEIGHT KG.	1.05

HORIZONTAL ADJUSTABLE

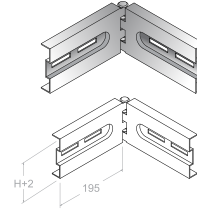

CODE NO. EPOXY POWDER COATING	HAI-LP
CODE NO. HOT DIP GALVANIZED	HAI-LH
THICKNESS MM.	2.0
WEIGHT KG.	1.12

HOLD DOWN CLAMP

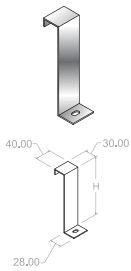

CODE NO. EPOXY POWDER COATING	HDC-LP
CODE NO. HOT DIP GALVANIZED	HDC-LH
THICKNESS MM.	2.0
WEIGHT KG.	0.21

FLANGE END

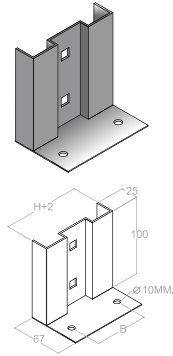

CODE NO. EPOXY POWDER COATING	FE-LP
CODE NO. HOT DIP GALVANIZED	FE-LH
THICKNESS MM.	2.0
WEIGHT KG.	0.6

END CAP

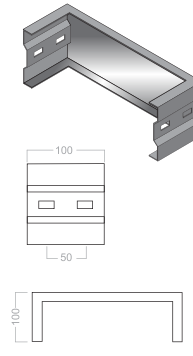

CODE NO. EPOXY POWDER COATING	EC-LP
CODE NO. HOT DIP GALVANIZED	EC-LH
THICKNESS MM.	2.0
WEIGHT KG.	5.65

COVER FOR CABLE LADDER

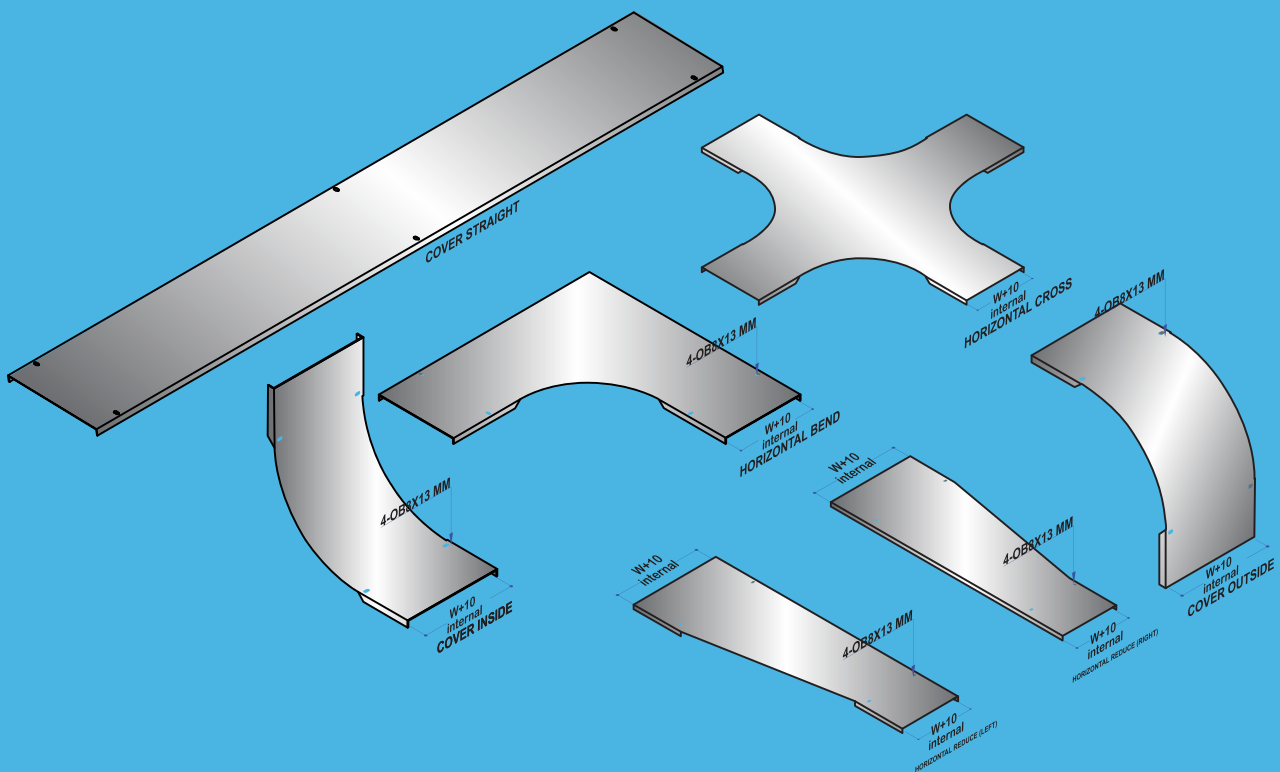

Ventilated Type HEAVY DUTY

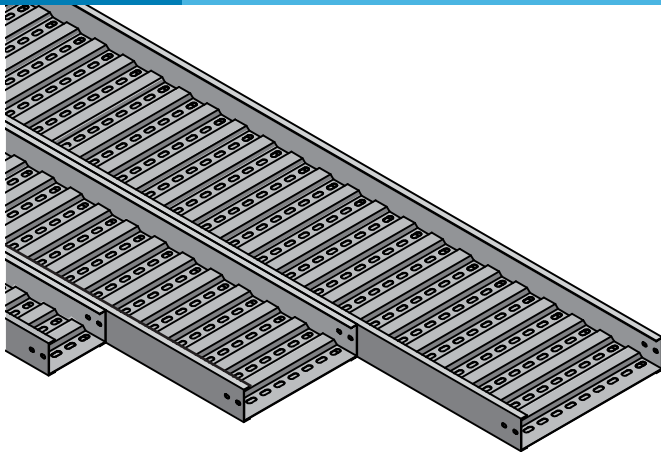

Description

Application

Material Selection

Deformation Standard Finishing Standard

Length (mm.) Height (mm.) Thickness (mm.) Side Rail Profile Assembly

VENTILATED TROUGH TYPE

General Indoor & Outdoor

- Hot Roll Mild Steel
- Stainless 304/L,316/L
- Electro Galvanized
- Galvanized Sheet
- NEMA VE-01 Certified
- Epoxy Powder Coating-ASTM D687
- Hot Dip Galvanized-ASTM A123

3000	6000 HDG (ONLY)
------	-----------------

100	150
-----	-----

2.0/1.6	2.0/2.0
---------	---------

U-Shape in
Welding

Detail :

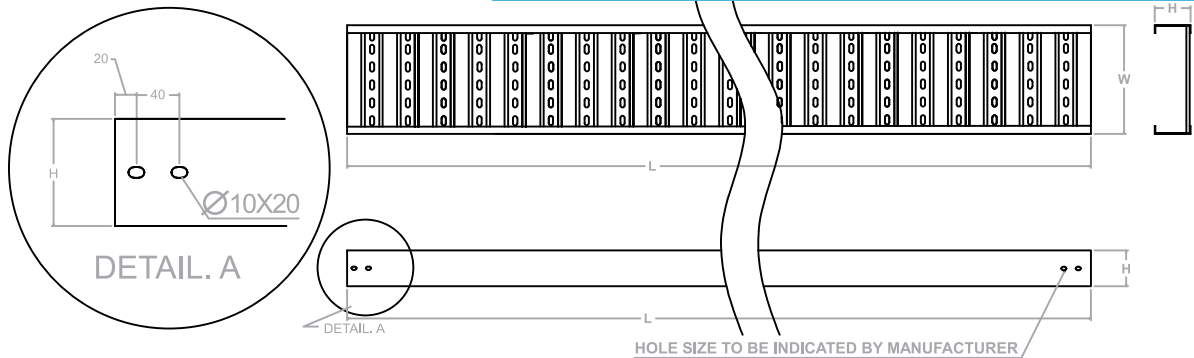

CODE NO. EPOXY POWDER COATING	CODE NO. HOT DIP GALVANIZED	CABLE TRAY SIZE	WEIGHT/KG/EA		
			TRAY	COVER	
VP 01	VH 01	100 X 100 X 3000	17.66	5.20	6.50
VP 02	VH 02	200 X 100 X 3000	21.65	8.97	11.21
VP 03	VH 03	300 X 100 X 3000	25.64	12.74	15.92
VP 04	VH 04	400 X 100 X 3000	29.64	16.50	20.63
VP 05	VH 05	500 X 100 X 3000	33.63	20.27	25.34
VP 06	VH 06	600 X 100 X 3000	37.62	24.01	30.05
VP 07	VH 07	700 X 100 X 3000	41.62	27.81	34.76
VP 08	VH 08	800 X 100 X 3000	45.61	31.58	39.35
VP 09	VH 09	900 X 100 X 3000	49.61	35.34	44.18
VP 10	VH 10	1000 X 100 X 3000	53.60	39.11	48.89
VP 12	VH 12	1200 X 100 X 3000	61.62	46.65	58.31

V = Ventilated Though (Corrugated Bottom), P = Epoxy Powder Coating, H = Hot Dip Galvanized

Ventilated Type HEAVY DUTY



FITTINGS

HORIZONTAL CROSS

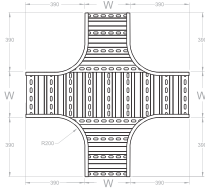
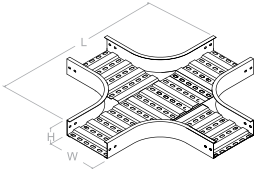
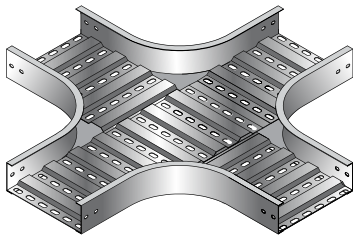

CODE NO. EPOXY POWDER COATING	CODE NO. HOT DIP GALVANIZED	CABLE TRAY SIZE (MM.)
HX-VP	HX-VH	W x H

HORIZONTAL REDUCE

LEFT

RIGHT

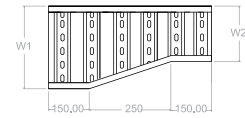
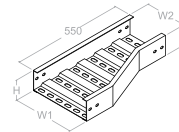
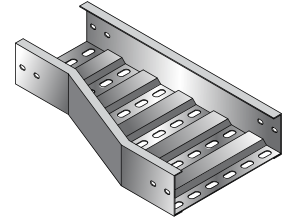
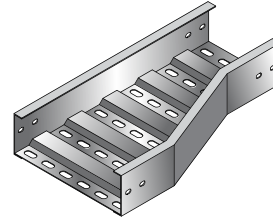

CODE NO. EPOXY POWDER COATING	CODE NO. HOT DIP GALVANIZED	CABLE TRAY SIZE (MM.)
HR-VP	HR-VH	W1, W2 x H

HORIZONTAL TEES

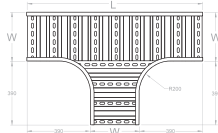
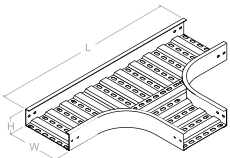
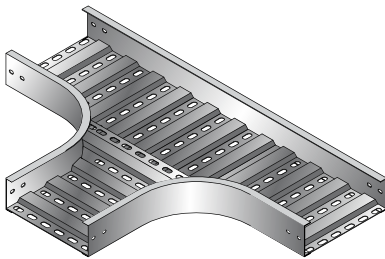

CODE NO. EPOXY POWDER COATING	CODE NO. HOT DIP GALVANIZED	CABLE TRAY SIZE (MM.)
HT-VP	HT-VH	W x H

VERTICAL INSIDE

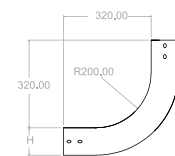
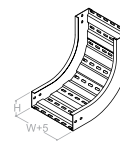
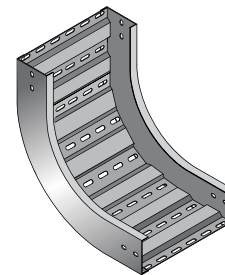

CODE NO. EPOXY POWDER COATING	CODE NO. HOT DIP GALVANIZED	CABLE TRAY SIZE (MM.)
90VI-VP	90VI-VH	W x H

HORIZONTAL BEND

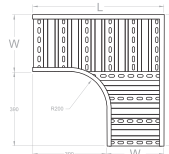
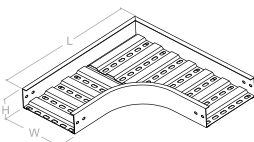
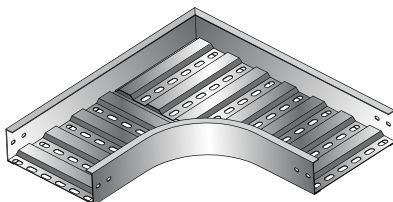

CODE NO. EPOXY POWDER COATING	CODE NO. HOT DIP GALVANIZED	CABLE TRAY SIZE
90HB-VP 01	90HB-VH 01	W x H x L

VERTICAL OUTSIDE

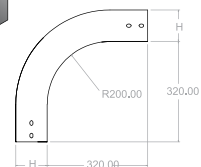
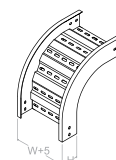
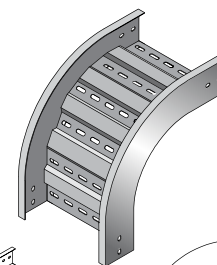

CODE NO. EPOXY POWDER COATING	CODE NO. HOT DIP GALVANIZED	CABLE TRAY SIZE (MM.)
90VO-VP 01	90VO-VH 01	W x H

Ventilated Type HEAVY DUTY



ACCESSORIES

SPLICE PLATE (OUT)

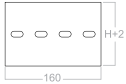

CODE NO. EPOXY POWDER COATING	SP-VP (OUT)
CODE NO. HOT DIP GALVANIZED	SP-VH (OUT)
THICKNESS MM.	2.0
WEIGHT KG.	0.52

SPLICE PLATE (IN)

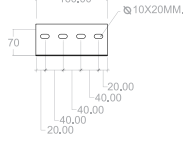
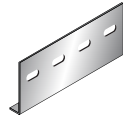

CODE NO. EPOXY POWDER COATING	SP-VP (IN)
CODE NO. HOT DIP GALVANIZED	SP-VH (IN)
THICKNESS MM.	2.0
WEIGHT KG.	1.05

HORIZONTAL ADJUSTABLE

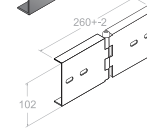
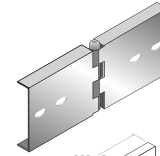

CODE NO. EPOXY POWDER COATING	HAJ-VP
CODE NO. HOT DIP GALVANIZED	HAJ-VH
THICKNESS MM.	2.0
WEIGHT KG.	1.12

VERTICAL ADJUSTABLE

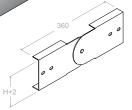
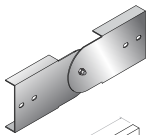

CODE NO. EPOXY POWDER COATING	VAJ-VP
CODE NO. HOT DIP GALVANIZED	VAJ-VH
THICKNESS MM.	2.0
WEIGHT KG.	1.2

END CAP

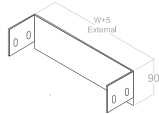
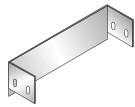

CODE NO. EPOXY POWDER COATING	EC-VP
CODE NO. HOT DIP GALVANIZED	EC-VH
THICKNESS MM.	2.0
WEIGHT KG.	0.2

FLANGE END

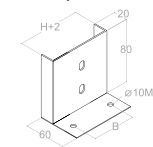
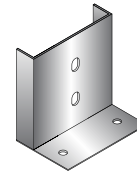

CODE NO. EPOXY POWDER COATING	FE-VP
CODE NO. HOT DIP GALVANIZED	FE-VH
THICKNESS MM.	2.0
WEIGHT KG.	0.6

COVER FOR VENTILATED TYPE (CORRUGATED)

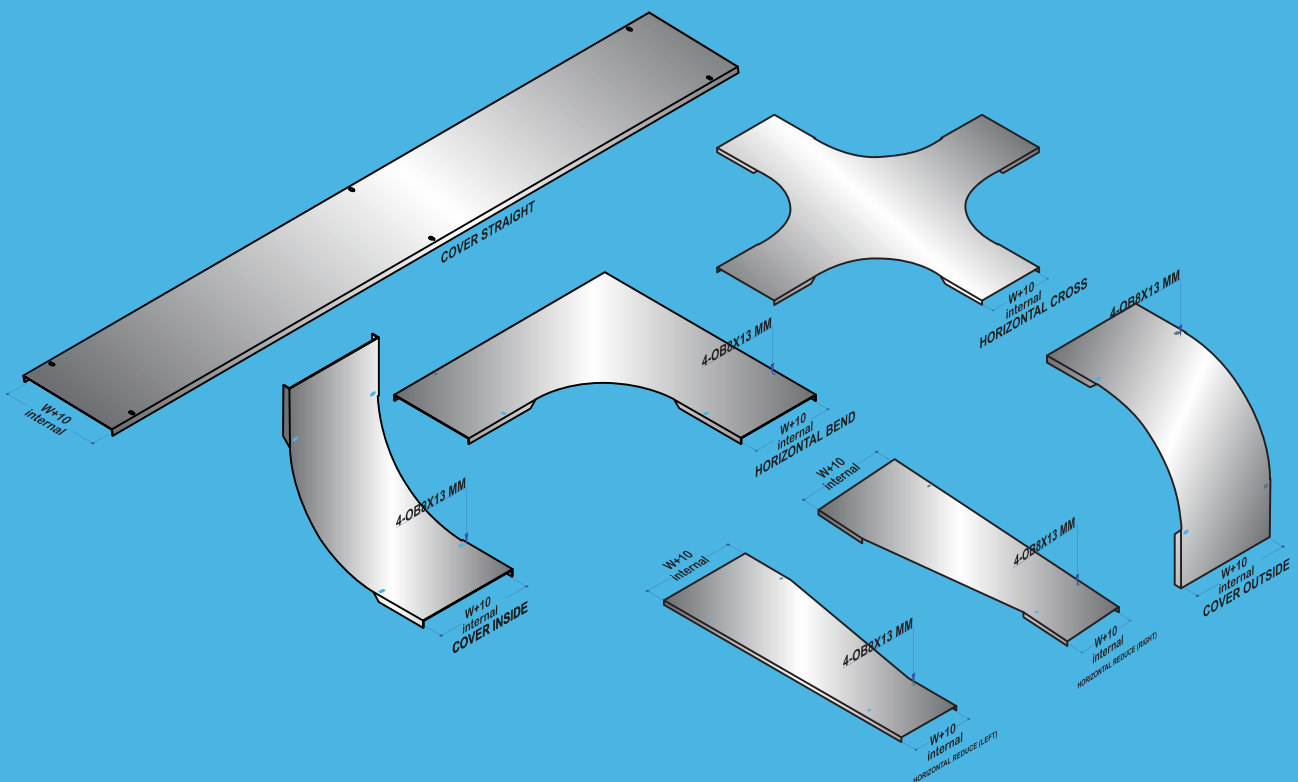

*V = Ventilated Though (Corrugated Bottom), P = Epoxy Powder Coating, H = Hot Dip Galvanized

Perforated Type



LIGHT / HEAVY DUTY

STRAIGHT SECTION

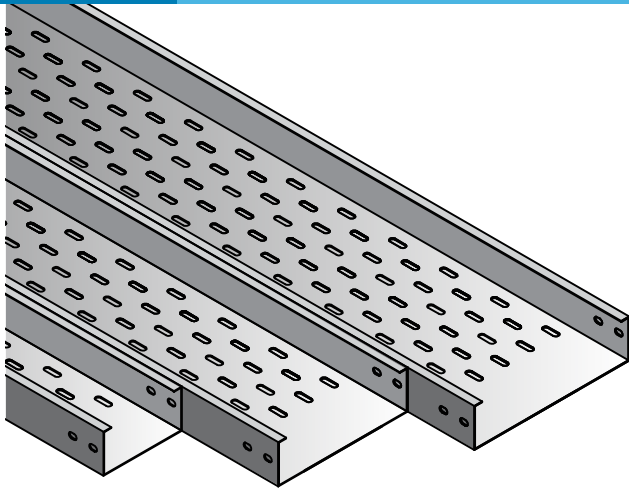

Manufacturing Standard Specification

Description
Application
Material Selection

PERFORATED TRAY TYPE

General Indoor / Outdoor

- Hot Roll Mild Steel
- Stainless 304(L) /316 (L)
- Electro Galvanized
- Galvanized Sheet

Deformation Standard
Finishing Standard

NEMA VE-01 Certified

Epoxy Powder Coating- ASTM D687

Hot Dip Galvanized-ASTM A123

Length (mm.)
Height (mm.)
Thickness (mm.)
Side Rail Profile

2440

100

2.0

1.6

U-Shape in

Detail :

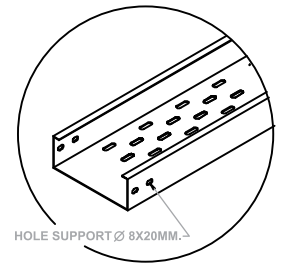
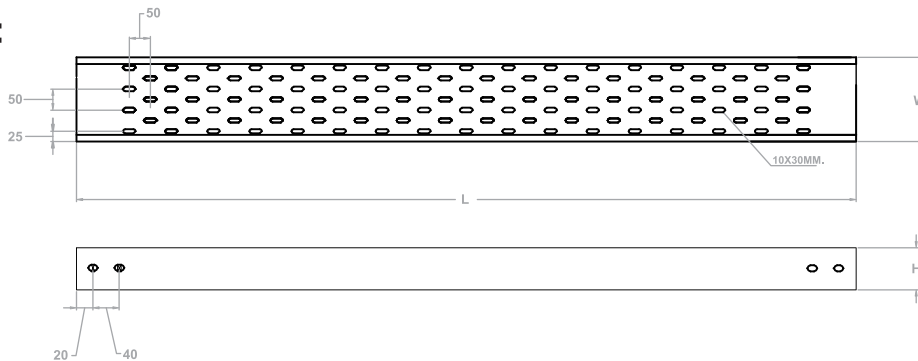

CODE NO. EPOXY POWDER COATING	CODE NO. HOT DIP GALVANIZED	PERFORATE TRAY SIZE W x H x L (MM.)	WEIGHT/KG/EA			
			PERFORATE TRAY		COVER	
			T = 1.6 MM.	T = 2.0 MM.	T = 1.6 MM.	T = 2.0 MM.
LVP 01	LVH 01	100 X 100 X 2440	10.02	12.40	4.01	5.02
LVP 02	LVH 02	200 X 100 X 2440	13.18	16.35	7.08	8.85
LVP 03	LVH 03	300 X 100 X 2440	16.35	20.31	10.14	12.68
LVP 04	LVH 04	400 X 100 X 2440	19.51	24.26	13.21	16.51
LVP 05	LVH 05	500 X 100 X 2440	22.68	28.22	16.27	20.34
LVP 06	LVH 06	600 X 100 X 2440	25.84	32.18	19.34	24.17
LVP 07	LVH 07	700 X 100 X 2440	29.10	36.13	22.40	28.00
LVP 08	LVH 08	800 X 100 X 2440	32.17	40.09	25.47	31.83
LVP 09	LVH 09	900 X 100 X 2440	35.34	44.05	28.53	35.66
LVP 10	LVH 10	1000 X 100 X 2440	38.50	48.00	31.60	39.50

*LV = Perforated Tray (Solid Bottom), P = Epoxy Powder Coating, H = Hot Dip Galvanized

Perforated Type

FITTINGS

HORIZONTAL CROSS

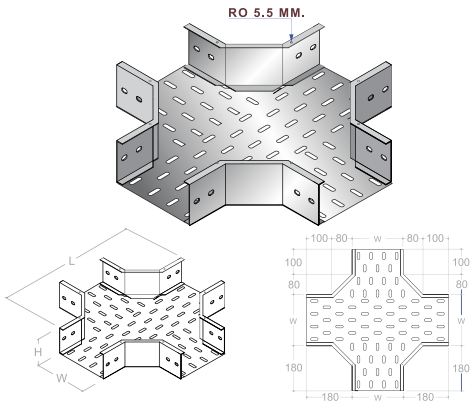

CODE NO. EPOXY POWDER COATING	CODE NO. HOT DIP GALVANIZED	PERFORATE TRAY SIZE (MM.)
HX-LVP	HX-LVH	W x H

HORIZONTAL REDUCE

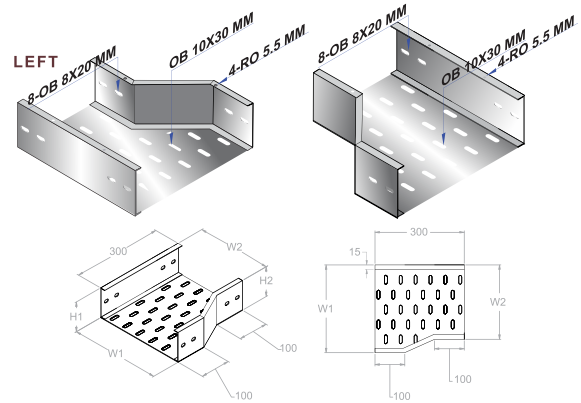

CODE NO. EPOXY POWDER COATING	CODE NO. HOT DIP GALVANIZED	PERFORATE TRAY SIZE (MM.)
HR-LVP	HR-LVH	W1, W2 X H

HORIZONTAL TEES

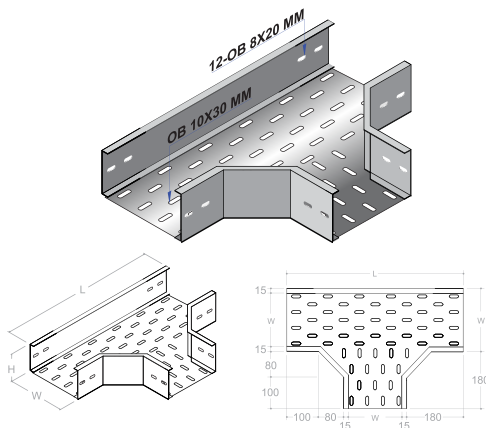

CODE NO. EPOXY POWDER COATING	CODE NO. HOT DIP GALVANIZED	PERFORATE TRAY SIZE (MM.)
HT-LVP	HT-LVH	W x H

VERTICAL INSIDE

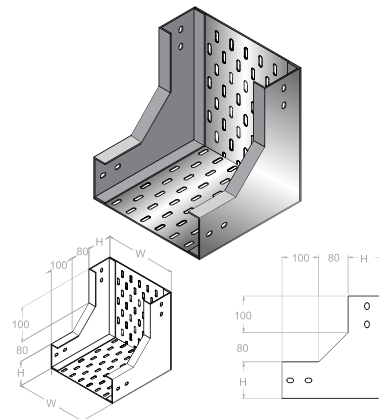

CODE NO. EPOXY POWDER COATING	CODE NO. HOT DIP GALVANIZED	PERFORATE TRAY SIZE (MM.)
90VI-LVP	90VI-LVH	W x H

HORIZONTAL BEND

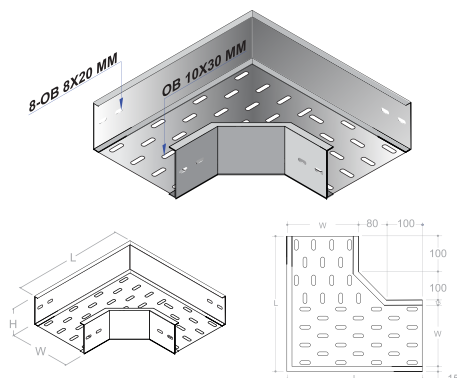

CODE NO. EPOXY POWDER COATING	CODE NO. HOT DIP GALVANIZED	PERFORATE TRAY SIZE (MM.)
90HB-LVP	90HB-LVH	W x H

VERTICAL OUTSIDE

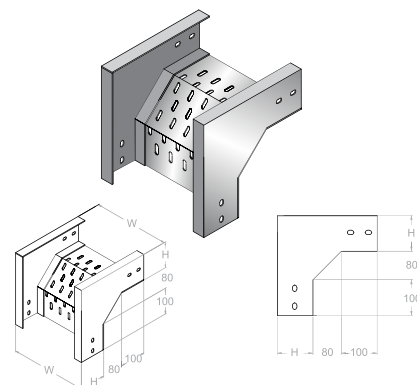

CODE NO. EPOXY POWDER COATING	CODE NO. HOT DIP GALVANIZED	PERFORATE TRAY SIZE (MM.)
90VO-LVP	90VO-LVH	W x H

*LV = Perforated Tray (Solid Bottom), P = Epoxy Powder Coating, H = Hot Dip Galvanized

Perforated Type

ACCESSORIES

SPLICE PLATE (OUT)

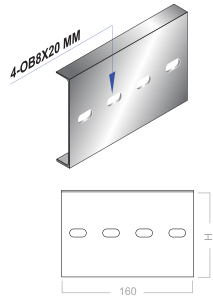

CODE NO. EPOXY POWDER COATING	SP-LVP (OUT)
CODE NO. HOT DIP GALVANIZED	SP-LVH (OUT)
THICKNESS MM.	2.0
WEIGHT KG.	0.52

VERTICAL ADJUSTABLE

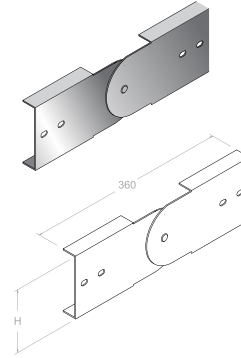

CODE NO. EPOXY POWDER COATING	VAJ-LVP
CODE NO. HOT DIP GALVANIZED	VAJ-LVH
THICKNESS MM.	2.0
WEIGHT KG.	1.05

HORIZONTAL ADJUSTABLE

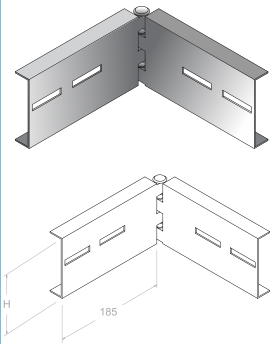

CODE NO. EPOXY POWDER COATING	H AJ-LVP
CODE NO. HOT DIP GALVANIZED	H AJ-LVH
THICKNESS MM.	2.0
WEIGHT KG.	1.12

HOLD DOWN CLAMP

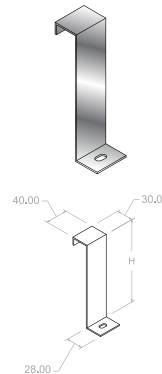

CODE NO. EPOXY POWDER COATING	HDC-LVP
CODE NO. HOT DIP GALVANIZED	HDC-LVH
THICKNESS MM.	2.0
WEIGHT KG.	0.21

COVER FOR PERFORATED TYPE (SOLID BOTTOM)

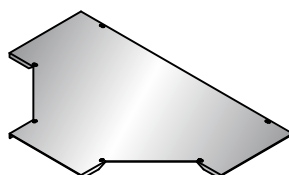
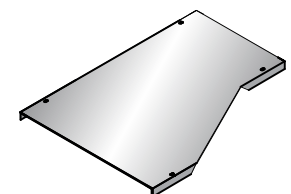
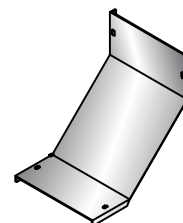
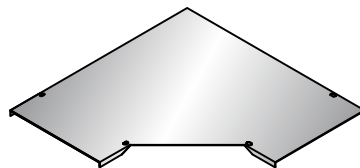
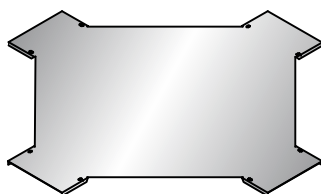
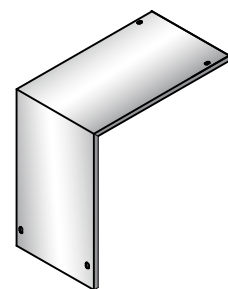
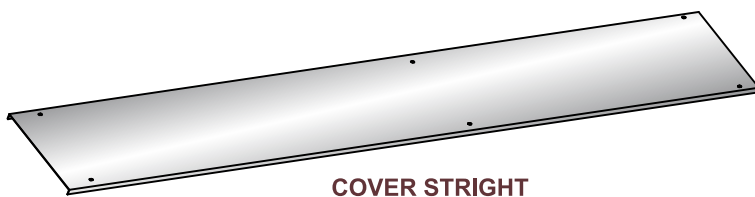

Wireway Type / CABLE DUCT



TRAY WITH COVER

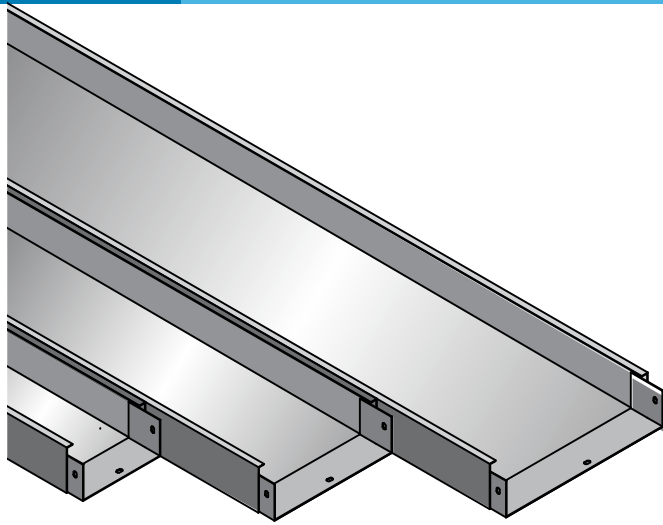

Manufacturing Standard Specification

Description

Application

Material Selection

Deformation Standard

Finishing Standard

Length (mm.)

Height (mm.)

Thickness (mm.)

METALLIC WIREWAY / Cable Duct

General Indoor & Outdoor

•Epoxy Powder Coating

•Hot Roll Mild Steel

NEMA VE-01 Certified

•Epoxy Powder Coating- ASTM D687

•Hot Dip Galvanized- ASTM A123

2440

100

0.8

1.0

1.2

1.6

2.0

Detail :

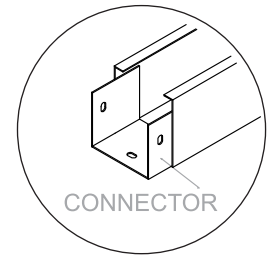
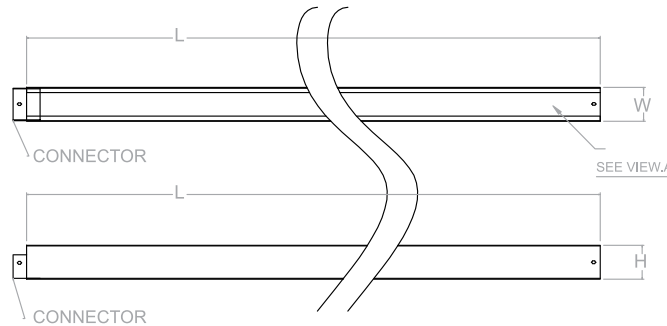
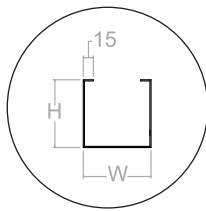

CODE NO. EPOXY POWDER COATING	CODE NO. HOT DIP GALVANIZED	THICKNESS : MM./ WEIGHT: KG.				
		0.8	1.0	1.2	1.6	2.0
WP 75 X 50 X 2440	WH 75 X 50 X 2440	4.70	5.87	7.04	9.17	11.28
WP 100 X 50 X 2440	WH 100 X 50 X 2440	5.48	6.85	8.22	10.73	13.23
WP 100 X 75 X 2440	WH 100 X 75 X 2440	6.27	7.84	9.41	12.31	15.21
WP 100 X 100 X 2440	WH 100 X 100 X 2440	7.06	8.82	10.58	13.90	17.18
WP 150 X 100 X 2440	WH 150 X 100 X 2440	8.62	10.77	12.92	17.05	21.08
WP 200 X 100 X 2440	WH 200 X 100 X 2440	10.18	12.72	15.26	20.13	24.97
WP 250 X 100 X 2440	WH 250 X 100 X 2440	11.73	14.66	17.59	23.24	28.86
WP 300 X 100 X 2440	WH 300 X 100 X 2440	13.29	16.61	19.93	26.36	32.76
WP 350 X 100 X 2440	WH 350 X 100 X 2440	14.85	18.56	22.27	29.47	36.65
WP 400 X 100 X 2440	WH 400 X 100 X 2440	16.41	20.51	24.61	32.59	40.55
WP 450 X 100 X 2440	WH 450 X 100 X 2440		22.45	26.94	35.70	44.44
WP 500 X 100 X 2440	WH 500 X 100 X 2440		24.40	29.28	38.81	48.33
WP 600 X 100 X 2440	WH 600 X 100 X 2440			33.94	45.04	56.12
WP 700 X 100 X 2440	WH 700 X 100 X 2440			38.63	51.41	63.91
WP 800 X 100 X 2440	WH 800 X 100 X 2440				57.50	71.92
WP 900 X 100 X 2440	WH 900 X 100 X 2440				63.87	79.71

*W = Wireway + COVER , P = Epoxy Powder Coating, H = Hot Dip Galvanized

Wireway Type



FITTINGS WITH COVER

HORIZONTAL CROSS

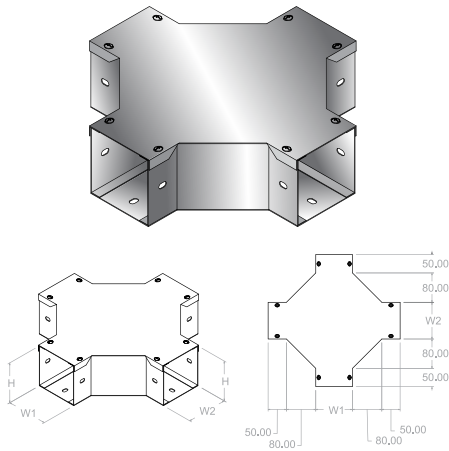

CODE NO. EPOXY POWDER COATING (MM.)	CODE NO. HOT DIP GALVANIZED (MM.)	TRAY SIZE (MM.)
HX-WP	HX-WH	W x H

HORIZONTAL REDUCE

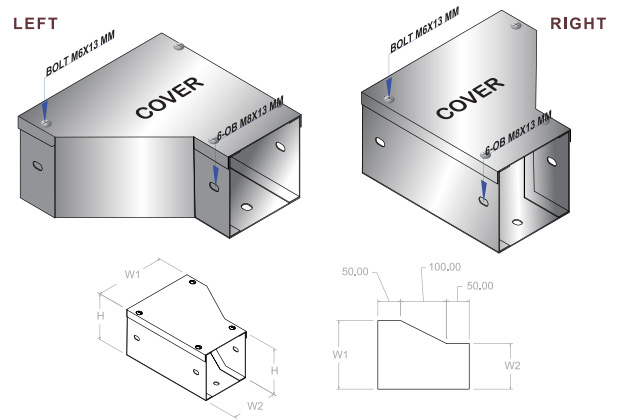

CODE NO. EPOXY POWDER COATING (MM.)	CODE NO. HOT DIP GALVANIZED (MM.)	TRAY SIZE (MM.)
HR-WP	HR-WH	W1, W2 x H

HORIZONTAL TEES

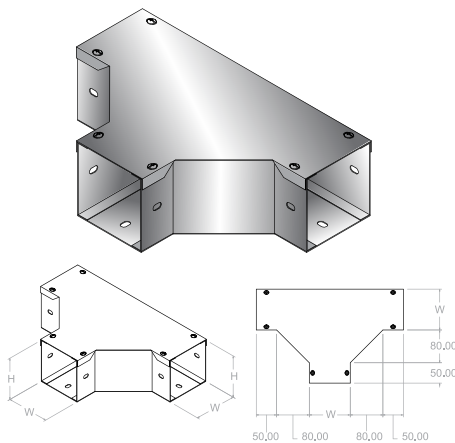

CODE NO. EPOXY POWDER COATING (MM.)	CODE NO. HOT DIP GALVANIZED (MM.)	TRAY SIZE (MM.)
HT-WP	HT-WH	W x H

VERTICAL INSIDE

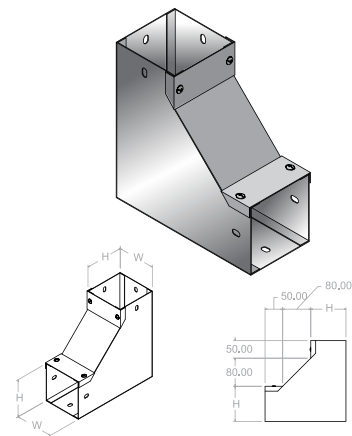

CODE NO. EPOXY POWDER COATING (MM.)	CODE NO. HOT DIP GALVANIZED (MM.)	TRAY SIZE (MM.)
90VI-WP	90VI-WH	W x H

HORIZONTAL BEND

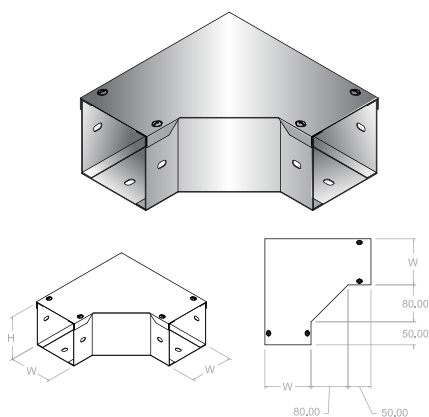

CODE NO. EPOXY POWDER COATING (MM.)	CODE NO. HOT DIP GALVANIZED (MM.)	TRAY SIZE (MM.)
90HB-WP	90HB-WH	W x H

VERTICAL OUTSIDE

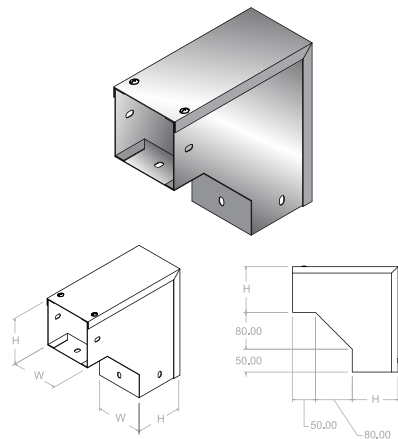

CODE NO. EPOXY POWDER COATING (MM.)	CODE NO. HOT DIP GALVANIZED (MM.)	TRAY SIZE (MM.)
90VO-WP	90VO-WH	W x H

Wireway Type



ACCESSORIES

CONNECTOR

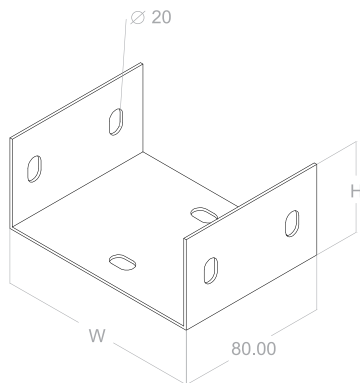
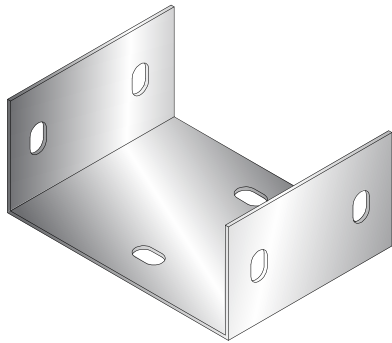

CODE NO.
EPOXY POWDER COATING (MM.)

WC - WP (W X H)

CODE NO.
HOT DIP GALVANIZED (MM.)

WC - WH (W X H)

END CAP

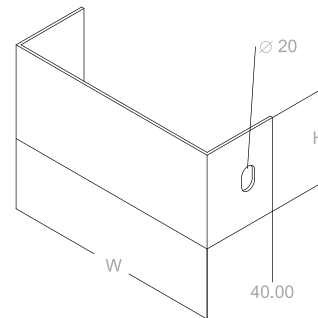
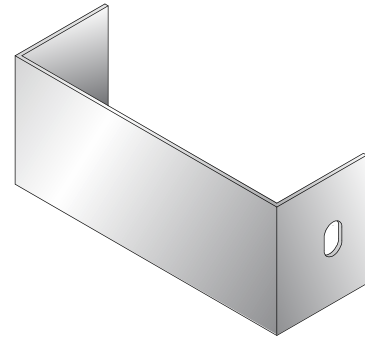

CODE NO.
EPOXY POWDER COATING (MM.)

EC - WP (W X H)

CODE NO.
HOT DIP GALVANIZED (MM.)

EC - WH (W X H)

HANGER SUPPORT

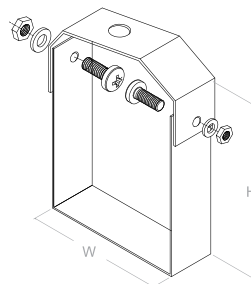
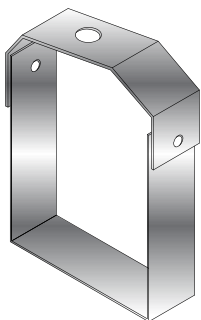

CODE NO.
EPOXY POWDER COATING (MM.)

HS - WP (W X H)

CODE NO.
HOT DIP GALVANIZED (MM.)

HS - WH (W X H)

FLANGE END

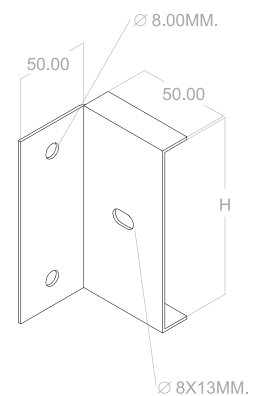
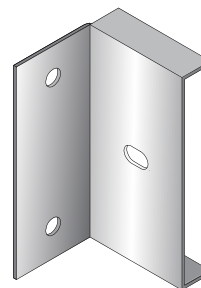

CODE NO.
EPOXY POWDER COATING (MM.)

FE - WP (W X H)

CODE NO.
HOT DIP GALVANIZED (MM.)

FE - WH (W X H)

*W = Wireway + COVER , P = Epoxy Powder Coating, H = Hot Dip Galvanized

C-Channel Type



STRAIGHT SECTION & FITTINGS

Manufacturing Standard Specification

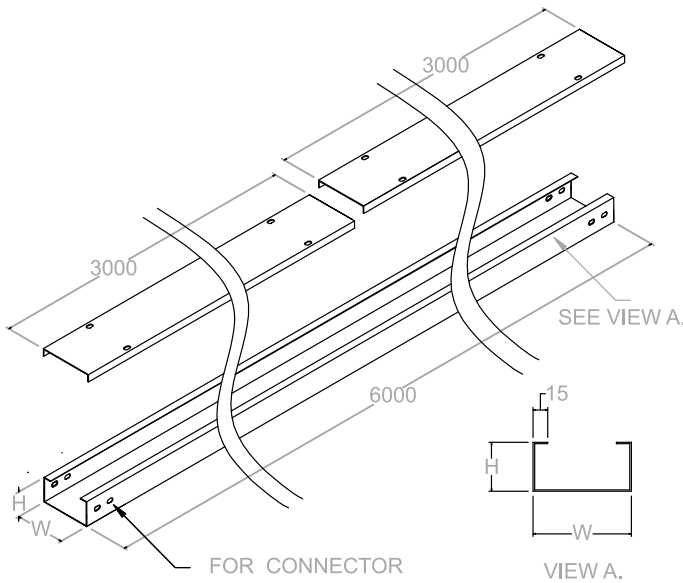

Description
Application
Material Selection
Deformation Standard
Finishing Standard

Lighting Tray
General Indoor
 • Hot Roll Mild Steel
NEMA VE-01 Certified
 • Epoxy Powder Coating-ASTM D687
 • Hot Dip Galvanized-ASTM A123

Length (mm.)
Height (mm.)
Thickness (mm.)
Cover Length (mm.)

6000
50 100
1.6 2.0
3000



CODE NO. EPOXY POWDER COATING	C-CHANNEL SIZE WxHxLxT (MM.)	C-CHANNEL WEIGHT / EA L 6000 MM.	WEIGHT COVER L3000 MM.		
			T 1.2	T 1.6	T 2.0
CCP-01	75 x 50 x 6000 x 1.6	14.84 KG.	2.85 KG.	3.80 KG.	4.75 KG.
CCP-02	100 x 50 x 6000 x 1.6	16.88 KG.	3.50 KG.	4.67 KG.	5.84 KG.
CCP-03	150 x 50 x 6000 x 1.6	21.12 KG.	3.50 KG.	4.67 KG.	5.84 KG.

HORIZONTAL CROSS

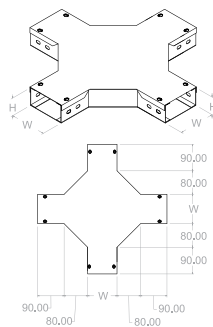
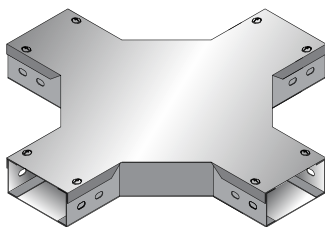

CODE NO. EPOXY POWDER COATING	C-CHANNEL SIZE WxHxT (MM.)	WEIGHT/EA
		T 1.6 MM.
HX-CCP-01	75X50X1.6	4.26 KG.
HX-CCP-02	100X50X1.6	4.97 KG.
HX-CCP-03	150X50X1.6	6.17 KG.

*with cover

HORIZONTAL TEES

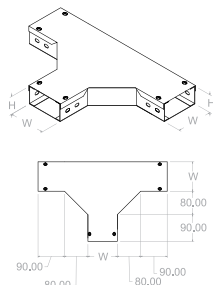
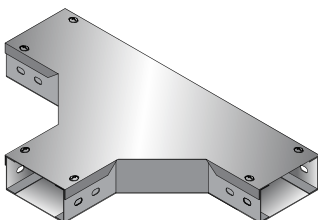

CODE NO. EPOXY POWDER COATING	C-CHANNEL SIZE WxHxT (MM.)	WEIGHT/EA
		T 2.0
HT-CCP01	75X50X1.6	3.41 KG.
HT-CCP02	100X50X1.6	3.98 KG.
HT-CCP03	150X50X1.6	4.94 KG.

*with cover

C-Channel Type



FITTINGS

HORIZONTAL BEND

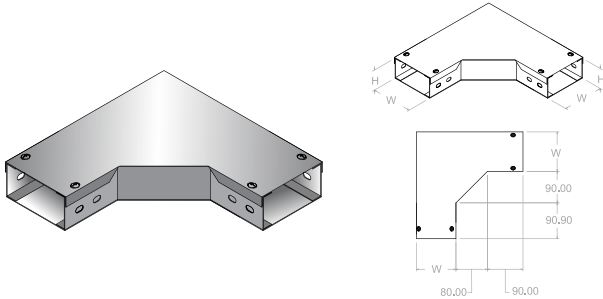

CODE NO. EPOXY POWDER COATING	C-CHANNEL SIZE WxHxT (MM.)	WEIGHT/EA
90HB-CCP01	75X50X1.6	2.27 KG.
90HB-CCP02	100X50X1.6	2.65 KG.
90HB-CCP03	150X50X1.6	3.29 KG.

HORIZONTAL REDUCE

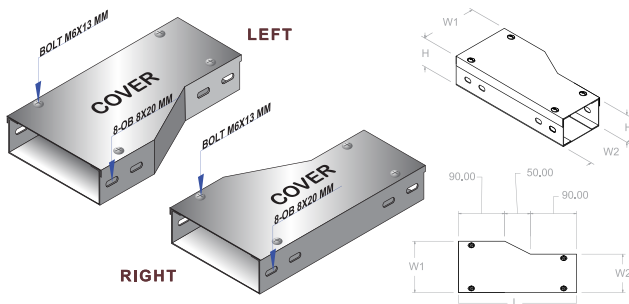

CODE NO. EPOXY POWDER COATING	C-CHANNEL SIZE	WEIGHT/EA
HR-CCP-01	W1, W2X50X1.6	2.27 KG.
HR-CCP-02	W1, W2X50X1.6	2.65 KG.
HR-CCP-03	W1, W2X50X1.6	3.29 KG.

*with cover

VERTICAL INSIDE

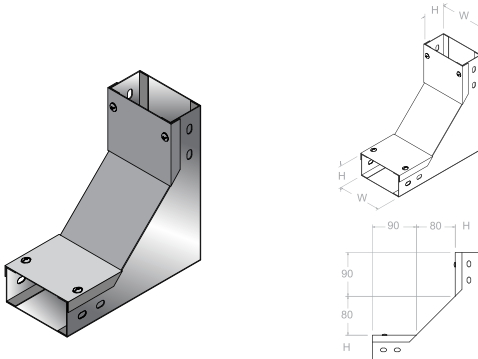

CODE NO. EPOXY POWDER COATING	C-CHANNEL SIZE WxHxT (MM.)	WEIGHT/EA
90VI-CCP01	75X50X1.6	2.27 KG.
90VI-CCP02	100X50X1.6	2.65 KG.
90VI-CCP03	150X50X1.6	3.29 KG.

*with cover

VERTICAL OUTSIDE

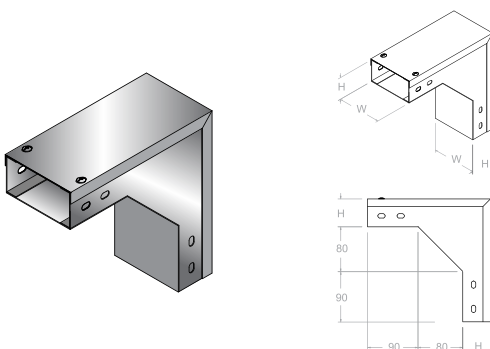

CODE NO. EPOXY POWDER COATING	C-CHANNEL SIZE WxHxT (MM.)	WEIGHT/EA
90VO-CCP01	75X50X1.6	2.27 KG.
90VO-CCP02	100X50X1.6	2.65 KG.
90VO-CCP03	150X50X1.6	3.29 KG.

*with cover

CONNECTOR

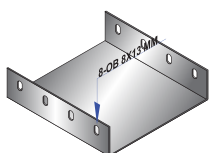

FLANGE END

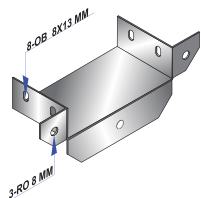

END CAP

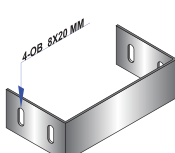

CODE NO.	DIMENSION (mm.)		
	HEIGHT (mm.)	THICKNESS (mm.)	WEIGHT (kg.)
CON-CCP 01	50	1.6	75 KG. 100 KG.

FOR ALL TYPES OF CABLE TRAY.

U-CHANNEL

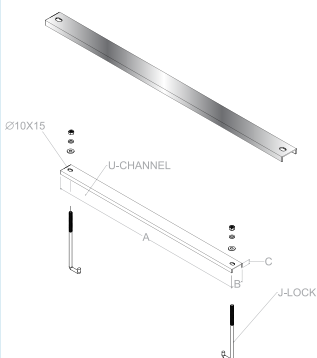

CODE NO. EPOXY POWDER COATING	U-CHANNEL LP/VP
CODE NO. HOT DIP GALVANIZED	U-CHANNEL LH/VH
THICKNESS MM.	2.0
WEIGHT KG.	1.09/M

J-LOCK

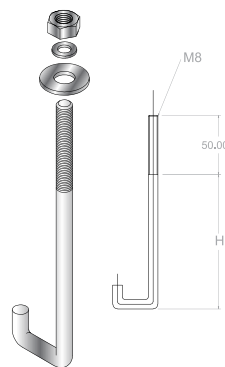

CODE NO. ELECTRO GALVANIZED	J-LOCK EG
CODE NO. STAINLESS STEEL	J-LOCK SS304
THICKNESS MM.	M8
WEIGHT KG.	0.2

BRACKET SUPPORT

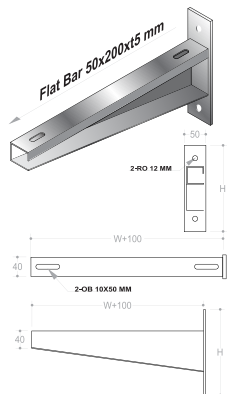

CODE NO. EPOXY POWDER COATING	BKS-LP/VP
CODE NO. HOT DIP GALVANIZED	BKS-LH/VH
THICKNESS MM.	2.0
WEIGHT KG.	1.05

PULL BOX

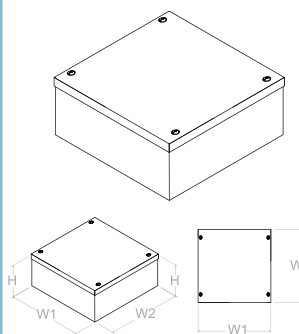

CODE NO. EPOXY POWDER COATING	PULLBOX EPOXY
CODE NO. HOT DIP GALVANIZED	PULLBOX HOT-DIP
THICKNESS MM.	1.6/2.0
WEIGHT KG.	XX.

SEPARATOR

SEPARATOR CABLE TRAY (3 HOLES)

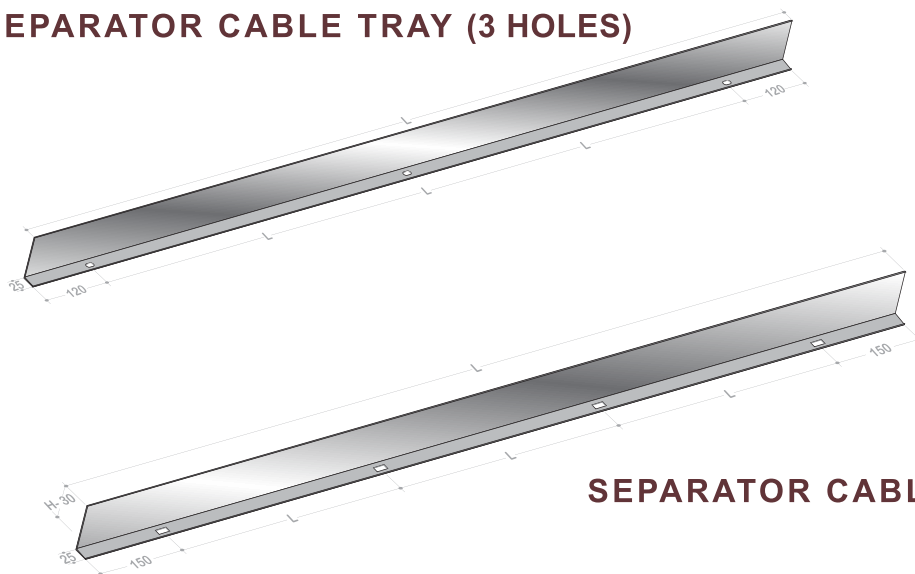

CODE NO. EPOXY POWDER COATING	SEP-LP/VP
CODE NO. HOT DIP GALVANIZED	SEP-LH/VH
THICKNESS MM.	2.0
WEIGHT KG.	5.65

SEPARATOR CABLE LADDER (4 HOLES)

Project References



Canon



Cataler



Honda



Kawasaki



Mitsubishi



Nidec



Nikon



Ryobi



Tenma Factory



Thai GCI Resitol



Toyota

Project References



Bangjak Refinery Plant



IRPC San 3



NPS Double A Power Plant



NPS Double A Power Plant 2



PTT GSP#6



SCG Rayong Tank Terminal



Siam Mitsui Wasterwater Plant



SCG Chemical



EGAT



BPEX

Project References



ABAC



Bangkok Hospital



K-Bank (HQ)



Bitec



Tesco Lotus



Makro



Ramada Hotel and Suit



Robinson



UOB



Siam Metal Works Industries Co., Ltd.

23/248-249 Moo 8, Petchkasem Rd., Om-Yai,
Sampran, Nakhon Pathom 73160 THAILAND

T: 02-802-4495 F: 02-455-5249

www.smcsiam.co.th

E-mail: sales@smcsiam.co.th